

GENERAL TECHNICAL SHEET

**NEW DUCATI GP84 SERIES
 POWER ELECTRONICS CAPACITORS
 AC/DC APPLICATIONS**

DUCATI energia has developed a **new and improved construction solution in the GP84** range of power electronic capacitors, suitable for both AC and DC power applications, and particularly suited for UPS equipment filter benches or for industrial power factor correction system.

Compared to the present series, the new GP84 range differs only for the configuration of the cap (terminal outputs) which is no longer metal but plastic, while the core of internal technology, the plastic dielectric film with the highly regenerating variable metallization profile, remains the same.



Designed to have the exact same size (see the figure below), starting in 2011 the new solution will replace the present one, with models with a diameter greater or equal to 75mm.

Revision: A	MADE by:	CHECKED by:
Date: 04/11/2010	RS/Con-dept. Ing. A.Govoni	RS/Con-dept. -

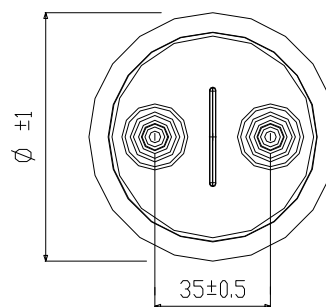
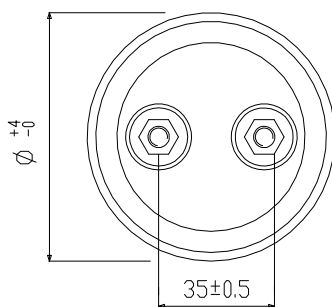
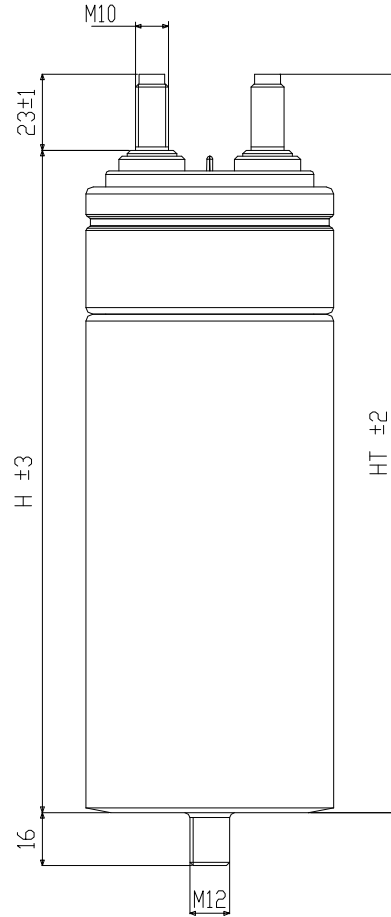
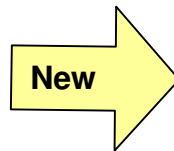
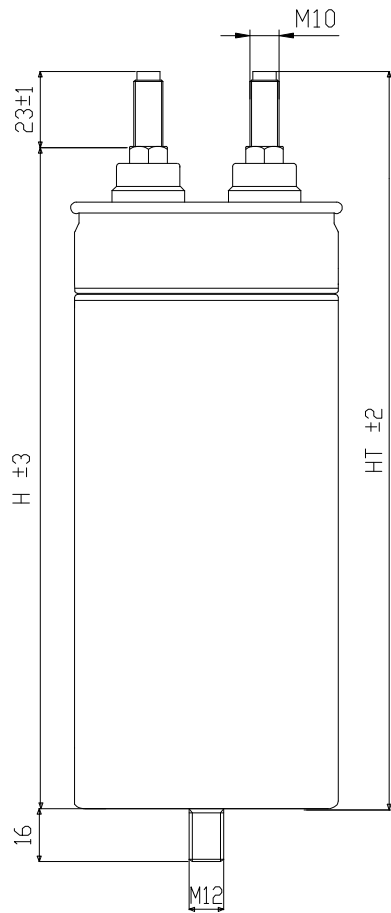
Present GP84 range - metal cap
New GP84 model - plastic cap

The PBT thermo-plastic cap, **flame-retardant V0 according to standard UL94**, is **extremely rigid and has optimum electrical insulation features**.

Revision: A	MADE by:	CHECKED by:
Date: 04/11/2010	RS/Con-dept. Ing. A.Govoni	RS/Con-dept. -

The **over-pressure safety system** (anti-explosion system) has the same internal execution – weakened cable with sliced profile; in case of an internal short-circuit at the end of its life the expansion of the cylinder case cuts electrical power thus preventing an explosion and material from seeping out. The rigidity of the new cap causes a **maximum expansion which is better controlled compared to the older solution** (see layout below).

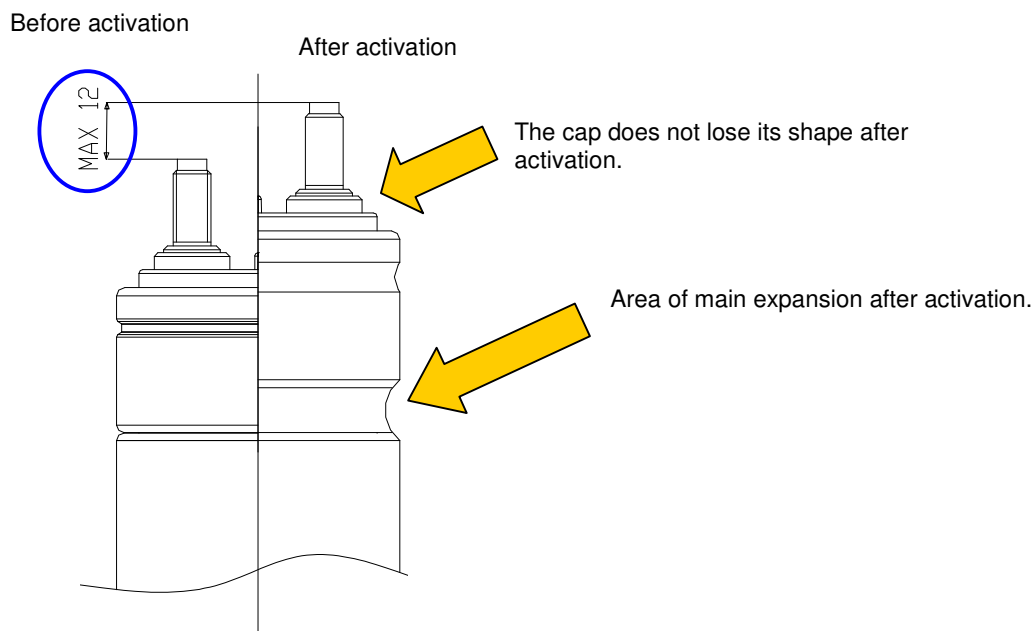

The following is a summary of the **main advantages** compared to the solution with the metal cap:

- Increases over-pressure anti-explosion safety system due to the more rigid cap and to the better controlled and reliable case-cap edge system.
- At the end of its life, in case of intervention by the anti-explosion device, the greater expansion of the container is better controlled, thus avoiding expansion of the metal cap.
- Improved the surface insulation properties, allowing the use of simplified and economical wiring (non-insulated terminals).
- Cancels the presence of leakage current caused by high frequency magnetic couplings on iron cap.

The new range has been designed in **total compliance with the Standard UL810 – component**.

In order to comply the new UL standard regarding the electrical spacing between an uninsulated live parts and an uninsulated live part of opposite polarity, or a grounded-metal part, it has been changed the plastic cover profile close to the stud only for the cover with diameter lower then 90mm.

Revision: A	MADE by:	CHECKED by:
Date: 04/11/2010	RS/Con-dept. Ing. A.Govoni	RS/Con-dept. -



Compared to the cover profile of diameter from 90 to 100 mm (not changed) the modification only for 75 – 85 mm diameter regard an addition of a partial plastic ring close to the M10 stud: please see figures below.

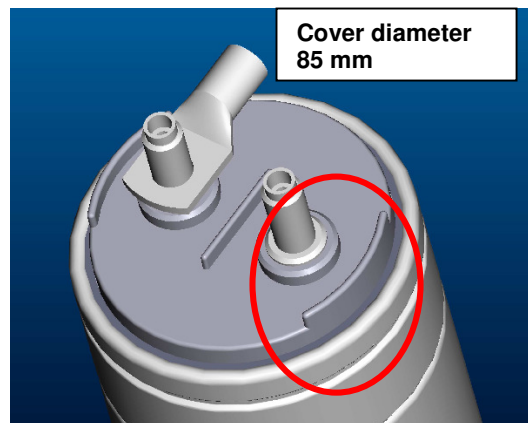
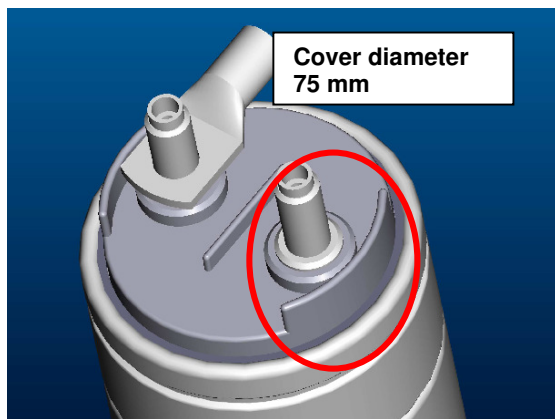

The following drawing shows the principal dimension of the added plastic ring for each diameter.

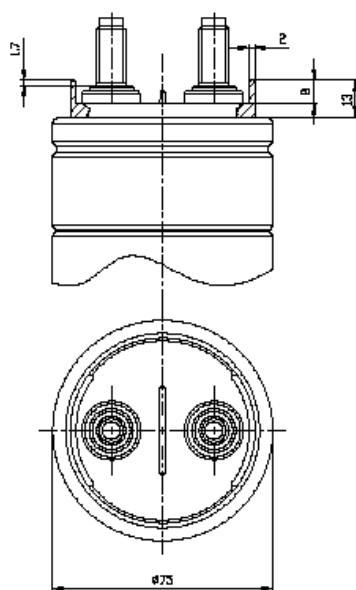

Cover diameter 75 mm

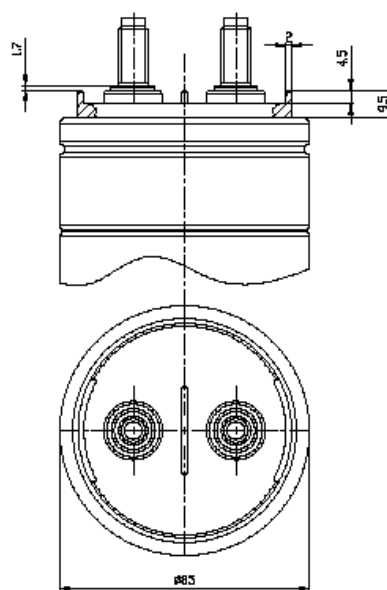

Cover diameter 85 mm

Revision: A	MADE by:	CHECKED by:
Date: 04/11/2010	RS/Con-dept. Ing. A.Govoni	RS/Con-dept. -